



MIRAI GLOBAL
POLYMERS PVT LTD

Your Trusted Partner in
Innovative Polymer Solutions





MIRAI GLOBAL
POLYMERS PVT LTD

Company Profile



ABOUT US

Mirai Global Polymers Pvt. Ltd. is a performance-driven polymer compounding company delivering advanced material solutions to meet the evolving needs of modern industries. Built on strong technical expertise and process excellence, we develop polymer compounds that combine consistency, reliability, and application-focused performance.

At Mirai Global Polymers, quality is embedded in every stage of our process. Through continuous innovation, responsible manufacturing practices, and a strong customer partnership approach, we strive to deliver future-ready polymer solutions that create long-term value across industries.

Today, Mirai Global Polymers proudly supports industries such as automotive, electrical & electronics , Healthcare and Household Products touching everyday lives through the materials we create. We are a growth-oriented, diversified, and forward-thinking organization committed to innovation that respects both people and the planet. Built on a sustainable foundation, we believe true progress comes from balancing technology with responsibility. Through strong partnerships, global sourcing, and an unwavering focus on customer satisfaction, we strive not just to supply polymers—but to **build trust, enable growth, and shape a better future together.**





Note from Director

I hope this message finds you well and thriving in your endeavors. Welcome to the family of **MIRAI GLOBAL POLYMERS** a dynamic and forward-thinking organization committed to excellence and innovation.

At **Mirai Global Polymers**, our journey started with a clear dream — to build a company that people can trust and feel proud to work with. From the beginning, our focus has been on honesty, quality, and long-term relationships. What we have achieved so far is possible only because of the support of our customers, partners, and our dedicated team.

We believe polymers are not just materials; they are a part of everyday life. That is why we work carefully and responsibly to create products that are reliable, safe, and useful. Innovation, continuous learning, and respect for the environment guide every decision we make.

As we move ahead, our goal is to grow together with our customers and contribute positively to society. I sincerely thank everyone who has been part of our journey. Together, we will continue to build a stronger, better, and more sustainable future.



Our Mission and Our Vision

Our mission at **Mirai Global Polymers Pvt. Ltd.** is to manufacture high-quality polymer compounds that meet the performance and application needs of our customers. We focus on using advanced compounding processes, strict quality control, and technical expertise to deliver reliable, consistent, and customized polymer solutions. We aim to build strong customer relationships while following safe, sustainable, and responsible manufacturing practices.



OUR MISSION

Our **Vision** is to become a trusted and leading polymer compounding company, known for quality, innovation, and customer satisfaction. We strive to continuously improve our products and processes, adopt sustainable practices, and support industries with future-ready polymer materials that contribute to growth, efficiency, and environmental responsibility.



OUR VISION

Products we offer

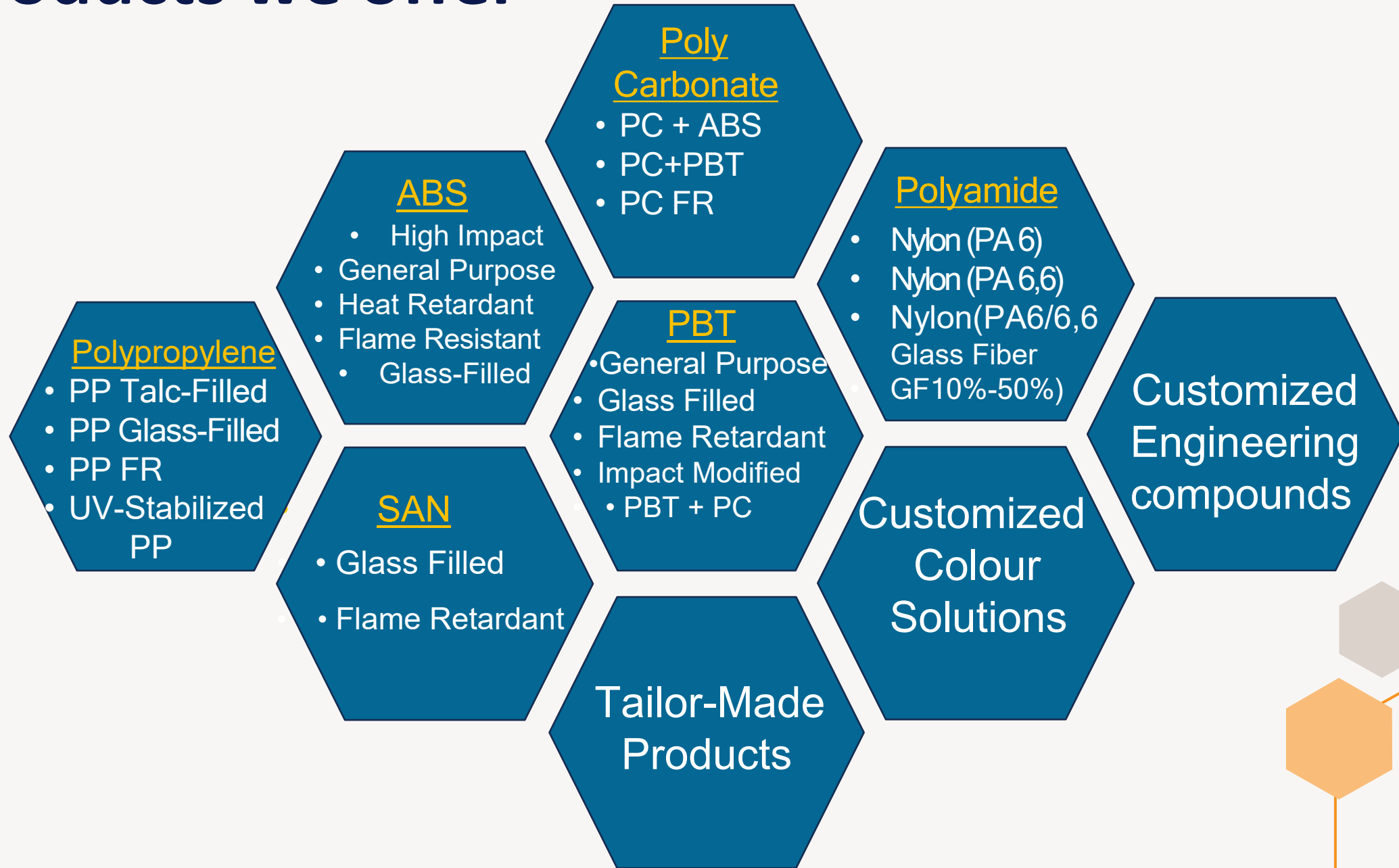

Our Quality Testing Facilities



Melt Flow Index Machine:

Purpose:

- Flow behavior of polymer
- Process consistency
- Injection & extrusion suitability

Function:

- Ensuring Flow Consistency



Universal Testing Machine:

Purpose:

- Tensile strength analysis
- Elongation & yield testing
- Quality verification of materials

Function:

- Ensuring tensile and Structural Strength



Izod / Charpy Impact Testing Machine:

Purpose:

- To measure impact strength of plastic
- To evaluate material toughness and durability

Purpose:

- Determines resistance of material to sudden shock or impact

Our Quality Testing Facilities



Hydrostatic Density Tester:

Purpose:

- To measure the density of polymer
- To verify material composition

Function:

- Ensuring consistency & quality



Colour Spectrophotometer:

Purpose:

- To check color accuracy
- To ensure color consistency

Function:

- Measures and compares color values with standard samples



Moisture Analyzer:

Purpose:

- Measuring moisture content
- Preventing processing defects
- Ensuring material quality

Function:

- Ensuring Proper Dryness of Polymer

Our Quality Testing Facilities

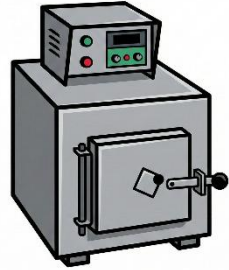

MUFFLE FURNACE

Ash Content Tester :

Purpose:

- To determine ash content in polymer
- To evaluate filler and inorganic content

Function:

- Burns material at high temperature to measure residue (ash %)



**NOTCH
CUTTER**

Notch Cutter:

Purpose:

- To prepare standard notched test specimens for impact testing
- To ensure accurate and repeatable test results

Function:

- Cuts precise V or U notches on plastic samples as per testing standards



**MOULDING
MACHINE**

Moulding Machine:

Purpose:

- To prepare standard dumbbell specimens for tensile testing
- To produce notched specimens for impact testing

Function:

- Forms standard polymer test specimen

Industries We Serve

Automotive

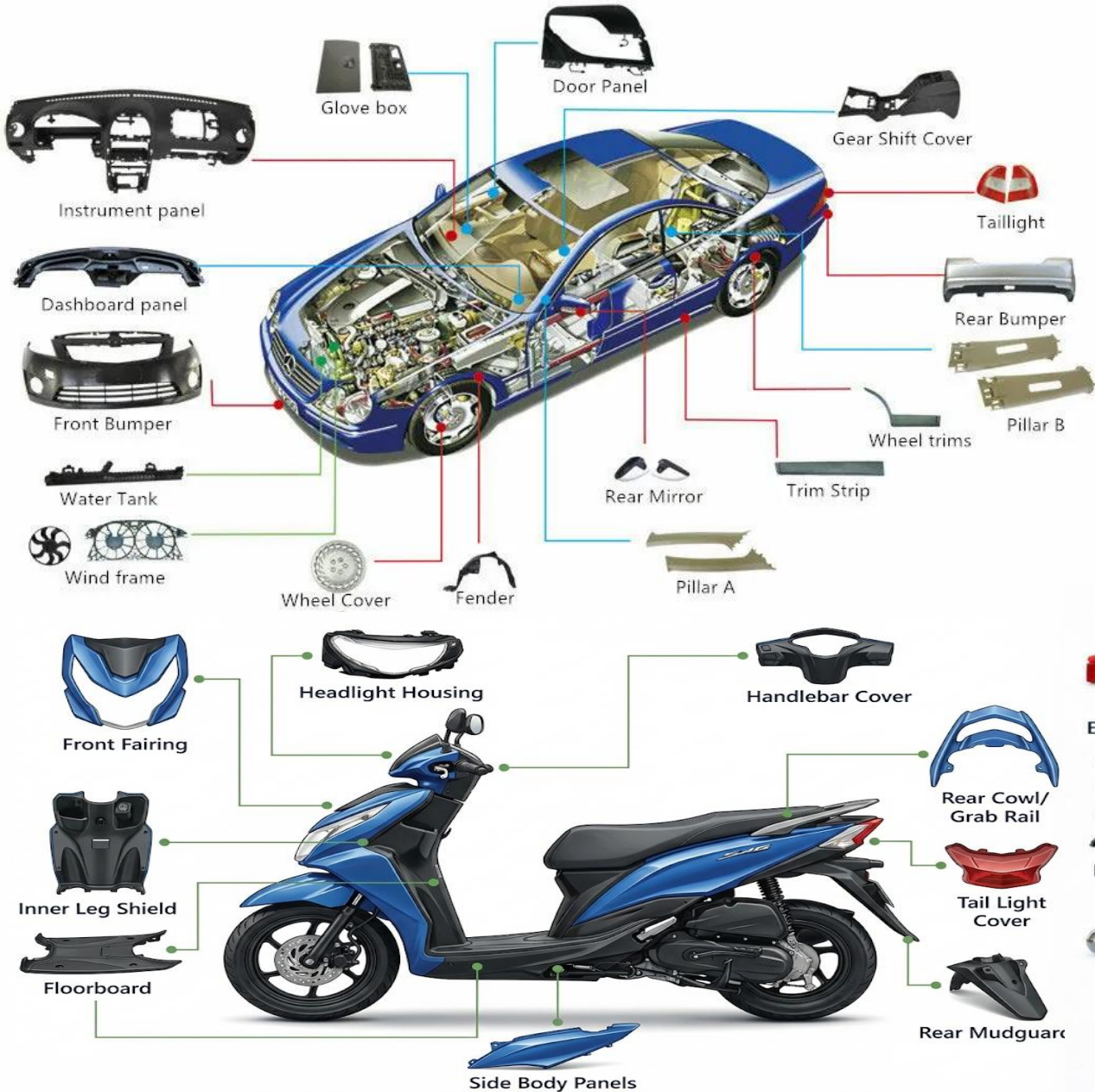

Industries We Serve

Medical :

Medical-Grade Plastic & Polymer Components



Electronics & Home Appliances :

Plastic Components for Home Appliances



Industries We Serve

Electrical :

Miniature Circuit Breaker (MCB)

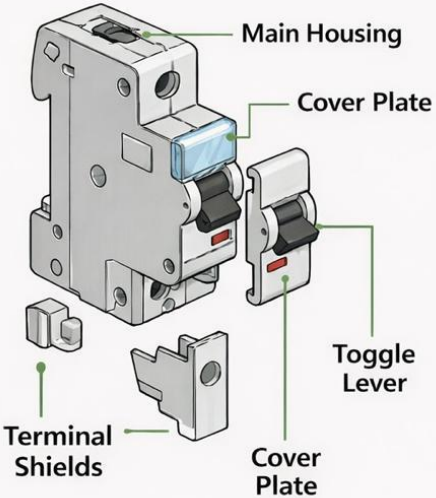

Contactor

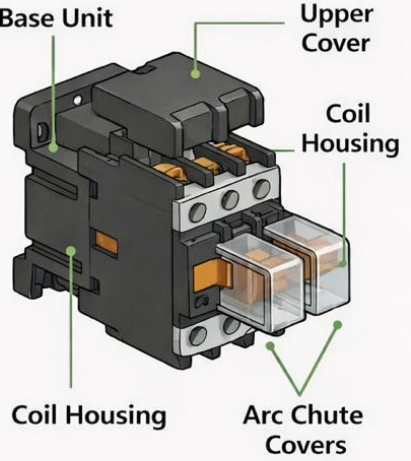

Gang of Switches

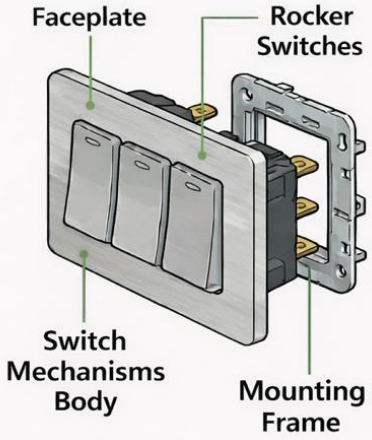

Furniture:

Plastic Components for Furniture



Casters

How We Work

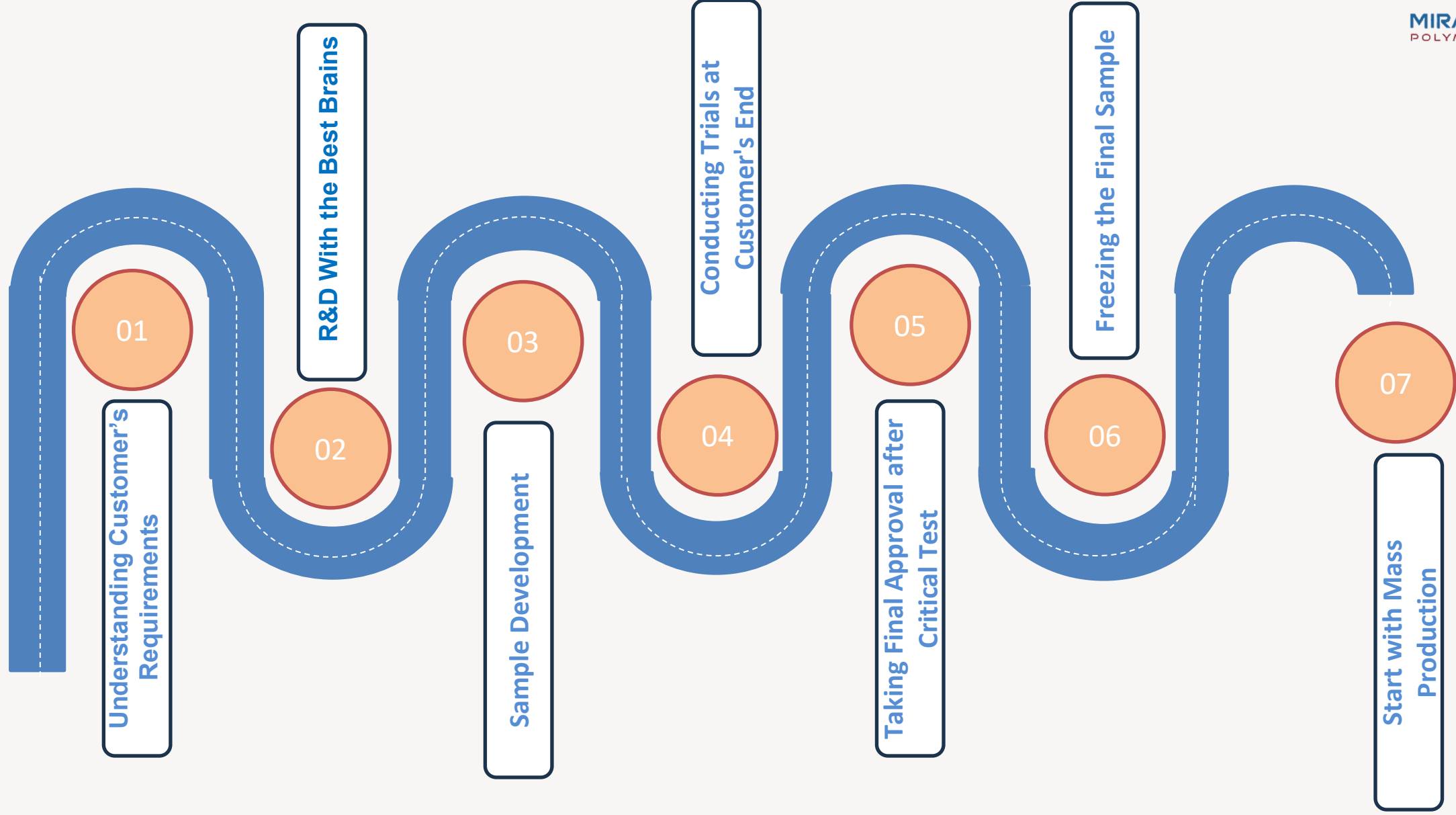

Our Manufacturing Facilities

Mirai Global Polymers Pvt. Ltd. has a well-organized manufacturing facility spread over **20,000 sq. ft.** area for polymer compounding. Our plant is equipped with a **twin screw extruder**, which helps us produce high-quality and uniform polymer compounds.

We also have a **1,800 sq. ft. office area** that supports our engineering, quality, and administrative teams. Our facility is designed to ensure smooth operations, consistent quality, and timely delivery while following safe and responsible manufacturing practices.



Contact Us

Mr. Khazan Singh(Director –Marketing)

Ph: +91-9990353535 Ph: +91-

7056777888

Mail: info@miraiglobalpolymers.com

Mail: sales@miraiglobalpolymers.com

Web- www.miraiglobalpolymers.com

Address: Suncity Industrial Park
Sector-M12 , IMT Manesar
Gurugram-122052 (Haryana) -India



Thank You !



MIRAI GLOBAL
POLYMERS PVT LTD

